

SERIES 24 AND 28 STANDARD AND LOW POWER PROGRAMMABLE READ-ONLY MEMORIES

SEPTEMBER 1979—REVISED AUGUST 1984

- Expanded Family of Standard and Low Power PROMs
- Titanium-Tungsten (Ti-W) Fuse Links for Reliable Low-Voltage Full-Family-Compatible Programming
- Full Decoding and Fast Chip Select Simplify System Design
- P-N-P Inputs for Reduced Loading On System Buffers/Drivers
- Each PROM Supplied With a High Logic Level Stored at Each Bit Location
- Applications Include:
 - Microprogramming/Firmware Loaders
 - Code Converters/Character Generators
 - Translators/Emulators
 - Address Mapping/Look-Up Tables

description

The 24 and 28 Series of monolithic TTL programmable read-only memories (PROMs) feature an expanded selection of standard and low-power PROMs. This expanded PROM family provides the system designer with considerable flexibility in upgrading existing designs or optimizing new designs. Featuring proven titanium-tungsten (Ti-W) fuse links with low-current MOS-compatible p-n-p inputs, all family members utilize a common programming technique designed to program each link with a 20-microsecond pulse.

The 4096-bit and 8192-bit PROMs are offered in a wide variety of packages ranging from 18-pin 300 mil-wide thru 24 pin 600 mil-wide. The 16,384-bit PROMs provide twice the bit density of the 8192-bit PROMs and are provided in a 24 pin 600 mil-wide package.

All PROMs are supplied with a logic-high output level stored at each bit location. The programming procedure will produce open-circuits in the Ti-W metal links, which reverses the stored logic level at the selected location. The procedure is irreversible; once altered, the output for that bit location is permanently programmed. Outputs that have never been altered may later be programmed to supply the opposite output level. Operation of the unit within the recommended operating conditions will not alter the memory content.

Active level(s) at the chip-select input(s) (\bar{S} or \bar{S}) enables all of the outputs. An inactive level at any chip-select input causes all outputs to be in the three-state, or off condition.

standard PROMs

The standard PROM members of Series 24 and 28 offer high performance for applications which require the uncompromised speed of Schottky technology. The fast chip-select access times allow additional decoding delays to occur without degrading speed performance.

TYPE NUMBER	PACKAGE [†] AND TEMPERATURE RANGE DESIGNATORS	OUTPUT CONFIGURATION [‡]	BIT SIZE (ORGANIZATION)	TYPICAL PERFORMANCE		
				ACCESS TIMES		POWER DISSIPATION
				ADDRESS	SELECT	
TBP24S10	MJ, J, N	▽	1024 Bits (256W × 4B)	35 ns	20 ns	375 mW
TBP24SA10	MJ, J, N	◊				
TBP28S42	MJ, J, N	▽	4096 Bits (512W × 8B)	35 ns	20 ns	500 mW
TBP28SA42	MJ, J, N	◊				
TBP28S46	MJW, JW, NW	▽				
TBP28SA46	MJW, JW, NW	◊				
TBP24S41	MJ, J, N	▽	4096 Bits (1024 × 4B)	40 ns	20 ns	475 mW
TBP24SA41	MJ, J, N	◊				
TBP24S81	MJ, J, N	▽	8192 Bits (2048 × 4B)	45 ns	20 ns	625 mW
TBP24SA81	MJ, J, N	◊				
TBP28S86A	MJW, JW, NW	▽	8192 Bits (1024 × 8B)	45 ns	20 ns	625 mW
TBP28SA86A	MJW, JW, NW	◊				
TBP28S2708A	NW	▽				
TBP28S166	NW	▽	16,384 Bits (2048W × 8B)	35 ns	15 ns	650 mW

[†] MJ and MJW designates full-temperature-range circuits (formerly 54 Family), J, JW, N, and NW designates commercial-temperature-range circuits (formerly 74 Family).

[‡] ▽ = three state, ◊ = open collector.

4

PROMS

SERIES 24 AND 28 STANDARD AND LOW-POWER PROGRAMMABLE READ-ONLY MEMORIES

low power PROMs

To upgrade systems utilizing MOS EPROMs or MOS PROMs, or when designing new systems which do not require maximum speed, the low-power PROM family offers the output drive and speed performance of bipolar technology, plus reduced power dissipation.

TYPE NUMBER	PACKAGE† AND TEMPERATURE RANGE DESIGNATORS	OUTPUT CONFIGURATION‡	BIT SIZE (ORGANIZATION)	TYPICAL PERFORMANCE		
				ACCESS TIMES		POWER DISSIPATION
				ADDRESS	SELECT	
TBP28L22	MJ, J, N	▽	2048 Bits (256W × 8B)	45 ns	20 ns	375 mW
TBP28LA22	MJ, J, N	◊				
TBP28L42	MJ, J, N	▽	4096 Bits (512W × 8B)	60 ns	30 ns	250 mW
TBP28L46	MJW, JW, NW	▽				
TBP28L86A	MJW, JW, NW	▽	8192 Bits (1024W × 8B)	80 ns	35 ns	350 mW
TBP28L166	NW	▽	16,384 Bits (2084W × 8B)	65 ns	30 ns	350 mW

†MJ and MJW designates full-temperature-range circuits (formerly 54 Family). J, JW, N, and NW designates commercial-temperature-range circuits (formerly 74 Family).

‡▽ = three state, ◊ = open collector.

schematics of inputs and outputs

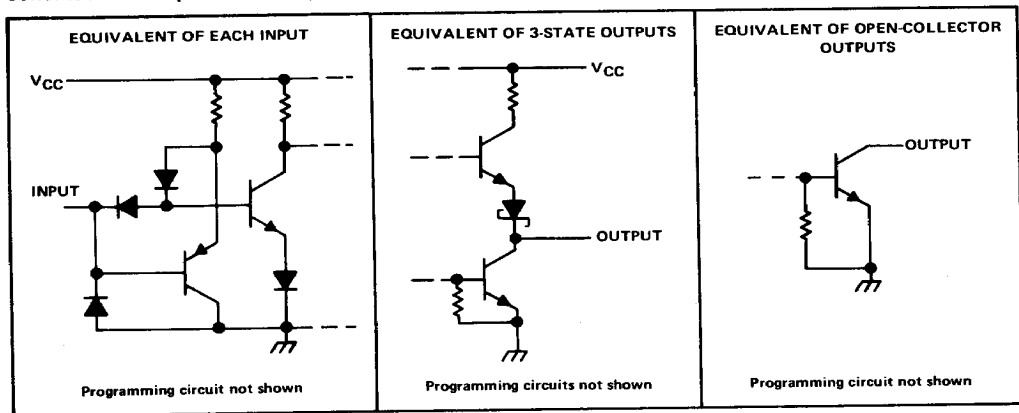

absolute maximum ratings over operating free-air temperature range (unless otherwise noted)

Supply voltage (see Note 1)	7 V
Input voltage	5.5 V
Chip-select peak input voltage (S, S1, S2) (see Note 2)	11 V
Off-state output voltage	5.5 V
Off-state peak output voltage (see Note 2)	16.25 V
Operating free-air temperature range: Full-temperature-range circuits (M suffix)	-55°C to 125°C
Commercial-temperature-range circuits	0°C to 70°C
Storage temperature range	-65°C to 150°C

NOTES: 1. Voltage values are with respect to network ground terminal.
2. These ratings apply only under the conditions described in the programming procedure.

4
PROMs

TBP24S10
1024 BIT (256 WORDS BY 4 BITS)
STANDARD PROGRAMMABLE READ-ONLY MEMORIES WITH 3-STATE OUTPUTS

logic symbol

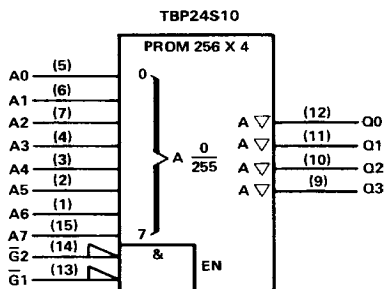

pin assignment

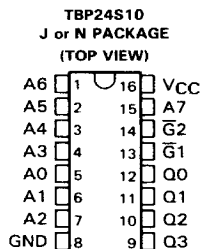

recommended operating conditions

PARAMETER	MJ			J OR N			UNIT
	MIN	NOM	MAX	MIN	NOM	MAX	
V _{CC} Supply voltage	4.5	5	5.5	4.75	5	5.25	V
V _{IH} High-level input voltage	2			2			V
V _{IL} Low-level input voltage			0.8			0.8	V
I _{OH} High-level output current			-2			-6.5	mA
I _{OL} Low-level output current						16	mA
T _A Operating free-air temperature range	-55		125	0		70	°C

electrical characteristics over recommended operating free-air temperature range (unless otherwise noted)

PARAMETER	TEST CONDITIONS [†]	MJ		J OR N			UNIT	
		MIN	TYP [‡]	MAX	MIN	TYP [‡]		MAX
V _{IK}	V _{CC} = MIN, I _I = -18 mA			-1.2		-1.2	V	
V _{OH}	V _{CC} = MIN, I _{OH} = MAX	2.4	3.1		2.4	3.1	V	
V _{OL}	V _{CC} = MIN, I _{OL} = 16 mA			0.5		0.5	V	
I _{OZH}	V _{CC} = MAX, V _O = 2.4 V			50		50	μA	
I _{OZL}	V _{CC} = MAX, V _O = 0.5 V			-50		-50	μA	
I _I	V _{CC} = MAX, V _I = 5.5 V			1		1	mA	
I _{IH}	V _{CC} = MAX, V _I = 2.7 V			25		25	μA	
I _{IL}	V _{CC} = MAX, V _I = 0.5 V			-0.25		-0.25	mA	
I _{OS} [§]	V _{CC} = MAX	-30		-100	-30	-100	mA	
I _{CC}	V _{CC} = MAX		75	100		75	100	mA

switching characteristics over recommended ranges of T_A and V_{CC} (unless otherwise noted)

PARAMETER	TEST CONDITIONS	MJ		J OR N			UNIT	
		MIN	TYP [‡]	MAX	MIN	TYP [‡]		MAX
t _a (A) Access time from address	C _L = 30 pF		35	75		35	55	ns
t _a (S) Access time from chip select (enable time)	See Note 3		20	40		20	35	ns
t _{dis} Disable time	C _L = 5 pF See Note 3		15	40		15	35	ns

[†]For conditions shown as MIN or MAX, use appropriate value specified under recommended operating conditions.

[‡]All typical values are at V_{CC} = 5 V, T_A = 25 °C.

[§]Not more than one output should be shorted at a time, and duration of the short circuit should not exceed one second.

NOTE 3: Load circuits and voltage waveforms are shown in Section 1.

4

PROMS

TBP24SA10
1024 BITS (256 WORDS BY 4 BITS)
STANDARD PROGRAMMABLE READ-ONLY MEMORIES WITH OPEN-COLLECTOR OUTPUTS

logic symbol

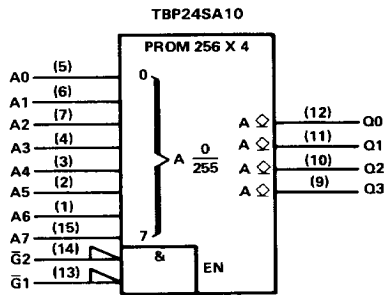

pin assignment

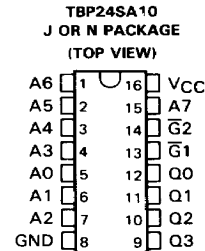

recommended operating conditions

PARAMETER		MJ			J OR N			UNIT
		MIN	NOM	MAX	MIN	NOM	MAX	
V _{CC}	Supply voltage	4.5	5	5.5	4.75	5	5.25	V
V _{IH}	High-level input voltage	2			2			V
V _{IL}	Low-level input voltage				0.8			V
V _{OH}	High-level output voltage				5.5			V
I _{OL}	Low-level output current				16			mA
T _A	Operating free-air temperature range	-55			125			°C

4

PROMS

electrical characteristics over recommended operating free-air temperature range (unless otherwise noted)

PARAMETER	TEST CONDITIONS [†]	MJ			J OR N			UNIT
		MIN	TYP [‡]	MAX	MIN	TYP [‡]	MAX	
V _{IK}	V _{CC} = MIN, I _I = -18 mA	-1.2			-1.2			V
I _{OH}	V _{CC} = MIN, V _{OH} = 2.4 V	0.05			0.05			mA
	V _{OH} = 5.5 V	0.1			0.1			
V _{OL}	V _{CC} = MIN, I _{OL} = 16 mA	0.5			0.45			V
I _I	V _{CC} = MAX, V _I = 5.5 V	1			1			mA
I _{IH}	V _{CC} = MAX, V _I = 2.7 V	25			25			μA
I _{IL}	V _{CC} = MAX, V _I = 0.5 V	-0.25			-0.25			mA
I _{CC}	V _{CC} = MAX	75 100			75 100			mA

switching characteristics over recommended ranges of T_A and V_{CC} (unless otherwise noted)

PARAMETER	TEST CONDITIONS	MJ			J OR N			UNIT
		MIN	TYP [‡]	MAX	MIN	TYP [‡]	MAX	
t _a (A)	Access time from address	35 75			35 65			ns
t _a (S)	Access time from chip select (enable time)	20 40			20 35			
t _{PLH}	Propagation delay time low-to-high-level output from chip select	15 40			20 35			ns

[†]For conditions shown as MIN or MAX, use appropriate value specified under recommended operating conditions.

[‡]All typical values are at V_{CC} = 5 V, T_A = 25°C.

NOTE 3: Load circuits and voltage waveforms are shown in Section 1.

TBP28S42
4096 BITS (512 WORDS BY 8 BITS)
STANDARD PROGRAMMABLE READ-ONLY MEMORIES WITH 3-STATE OUTPUTS

logic symbol

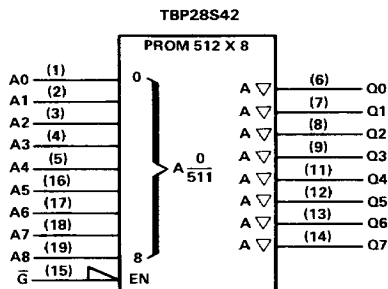

pin assignment

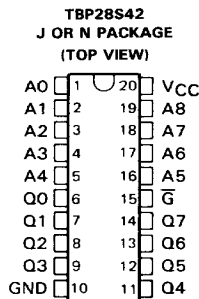

recommended operating conditions

PARAMETER		MJ			J OR N			UNIT
		MIN	NOM	MAX	MIN	NOM	MAX	
V _{CC}	Supply voltage	4.5	5	5.5	4.75	5	5.25	V
V _{IH}	High-level input voltage	2			2			V
V _{IL}	Low-level input voltage			0.8			0.8	V
I _{OH}	High-level output current			-2			-6.5	mA
I _{OL}	Low-level output current			16			16	mA
T _A	Operating free-air temperature range	-55		125	0		70	°C

electrical characteristics over recommended operating free-air temperature range (unless otherwise noted)

PARAMETER	TEST CONDITIONS [†]	MJ			J OR N			UNIT
		MIN	TYP [‡]	MAX	MIN	TYP [‡]	MAX	
V _{IK}	V _{CC} = MIN, I _I = -18 mA			-1.2			-1.2	V
V _{OH}	V _{CC} = MIN, I _{OH} = MAX	2.4	3.1		2.4	3.1		V
V _{OL}	V _{CC} = MIN, I _{OL} = 16 mA			0.5			0.5	V
I _{OZH}	V _{CC} = MAX, V _O = 2.4 V			50			50	μA
I _{OZL}	V _{CC} = MAX, V _O = 0.5 V			-50			-50	μA
I _I	V _{CC} = MAX, V _I = 5.5 V			1			1	mA
I _{IH}	V _{CC} = MAX, V _I = 2.7 V			25			25	μA
I _{IL}	V _{CC} = MAX, V _I = 0.5 V			-0.25			-0.25	mA
I _{OS} [§]	V _{CC} = MAX	-30		-100	-30		-100	mA
I _{CC}	V _{CC} = MAX		100	135		100	135	mA

switching characteristics over recommended ranges of T_A and V_{CC} (unless otherwise noted)

PARAMETER	TEST CONDITIONS	MJ			J OR N			UNIT
		MIN	TYP [‡]	MAX	MIN	TYP [‡]	MAX	
t _{a(A)}	Access time from address		35	70		35	60	ns
t _{a(S)}	Access time from chip select (enable time)		20	45		20	45	ns
t _{dis}	Disable time		15	45		15	40	ns

[†]For conditions shown as MIN or MAX, use appropriate value specified under recommended operating conditions.

[‡]All typical values are at V_{CC} = 5 V, T_A = 25 °C.

[§]Not more than one output should be shorted at a time, and duration of the short circuit should not exceed one second.

NOTE 3: Load circuits and voltage waveforms are shown in Section 1.

4

PROMS

TBP28SA42
4096 BITS (512 WORDS BY 8 BITS)
STANDARD PROGRAMMABLE READ-ONLY MEMORIES WITH OPEN-COLLECTOR OUTPUTS

logic symbol

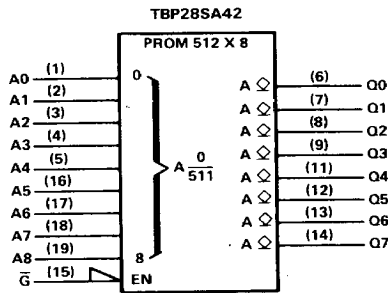

pin assignment

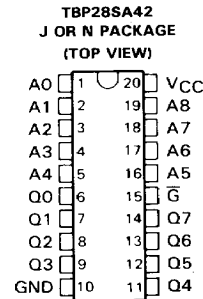

recommended operating conditions

PARAMETER	DESCRIPTION	MJ			J OR N			UNIT
		MIN	NOM	MAX	MIN	NOM	MAX	
V _{CC}	Supply voltage	4.5	5	5.5	4.75	5	5.25	V
V _{IH}	High-level input voltage	2			2			V
V _{IL}	Low-level input voltage			0.8			0.8	V
V _{OH}	High-level output voltage			5.5			5.5	V
I _{OL}	Low-level output current			16			16	mA
T _A	Operating free-air temperature range	-55		125	0		70	°C

4

PROMS

electrical characteristics over recommended operating free-air temperature range (unless otherwise noted)

PARAMETER	TEST CONDITIONS [†]	MJ		J OR N		UNIT	
		MIN	TYP [‡]	MAX	MIN		TYP [‡]
V _{IK}	V _{CC} = MIN, I _I = -18 mA			-1.2		-1.2	V
I _{OH}	V _{CC} = MIN, V _{OH} = 2.4 V			0.05		0.05	mA
	V _{OH} = 5.5 V			0.1		0.1	mA
V _{OL}	V _{CC} = MIN, I _{OL} = 16 mA			0.5		0.5	V
I _I	V _{CC} = MAX, V _I = 5.5 V			1		1	mA
I _{IH}	V _{CC} = MAX, V _I = 2.7 V			25		25	μA
I _{IL}	V _{CC} = MAX, V _I = 0.5 V			-0.25		-0.25	mA
I _{CC}	V _{CC} = MAX	105		135	105	135	mA

switching characteristics over recommended ranges of T_A and V_{CC} (unless otherwise noted)

PARAMETER	TEST CONDITIONS	MJ		J OR N		UNIT		
		MIN	TYP [‡]	MAX	MIN		TYP [‡]	MAX
t _{a(A)}	Access time from address			35	75	35	65	ns
t _{a(S)}	Access time from chip select (enable time)			20	45	20	35	ns
t _{PLH}	Propagation delay time low-to-high-level output from chip select			15	45	15	35	ns

[†]For conditions shown as MIN or MAX, use appropriate value specified under recommended operating conditions.

[‡]All typical values are at V_{CC} = 5 V, T_A = 25 °C.

NOTE 3: Load circuits and voltage waveforms are shown in Section 1.

TBP28S46
4096 BITS (512 WORDS BY 8 BITS)
STANDARD PROGRAMMABLE READ-ONLY MEMORIES WITH 3-STATE OUTPUTS

logic symbol

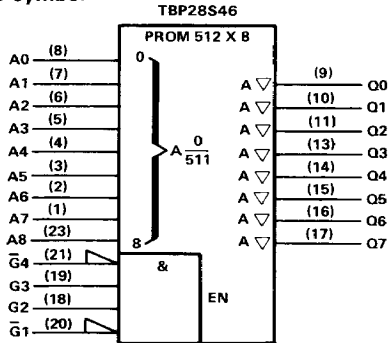

pin assignment

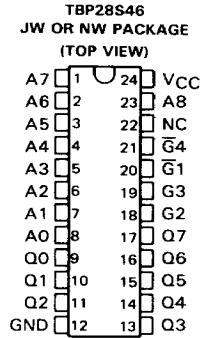

recommended operating conditions

PARAMETER	MJW			JW OR NW			UNIT
	MIN	NOM	MAX	MIN	NOM	MAX	
V _{CC} Supply voltage	4.5	5	5.5	4.75	5	5.25	V
V _{IH} High-level input voltage	2			2			V
V _{IL} Low-level input voltage			0.8			0.8	V
I _{OH} High-level output current			-2			-6.5	mA
I _{OL} Low-level output current			16			16	mA
T _A Operating free air temperature range	-55		125	0		70	°C

electrical characteristics over recommended operating free-air temperature range (unless otherwise noted)

PARAMETER	TEST CONDITIONS [†]	MJW			JW OR NW			UNIT
		MIN	TYP [‡]	MAX	MIN	TYP [‡]	MAX	
V _{IK}	V _{CC} = MIN, I _I = -18 mA			-1.2			-1.2	V
V _{OH}	V _{CC} = MIN, I _{OH} = MAX	2.4	3.1		2.4	3.1		V
V _{OL}	V _{CC} = MIN, I _{OL} = 16 mA			0.5			0.5	V
I _{OZH}	V _{CC} = MAX, V _O = 2.4 V			50			50	μA
I _{OZL}	V _{CC} = MAX, V _O = 0.5 V			-50			-50	μA
I _I	V _{CC} = MAX, V _I = 5.5 V			1			1	mA
I _{IH}	V _{CC} = MAX, V _I = 2.7 V			25			25	μA
I _{IL}	V _{CC} = MAX, V _I = 0.5 V			-0.25			-0.25	mA
I _{OS} [§]	V _{CC} = MAX	-15		-100	-20		-100	mA
I _{CC}	V _{CC} = MAX		100	135		100	135	mA

switching characteristics over recommended ranges of T_A and V_{CC} (unless otherwise noted)

PARAMETER	TEST CONDITIONS	MJW			JW OR NW			UNIT
		MIN	TYP [‡]	MAX	MIN	TYP [‡]	MAX	
t _{a(A)} Access time from address	C _L = 30 pF		35	70		35	60	ns
t _{a(S)} Access time from chip select (enable time)	See Note 3		20	45		20	35	ns
t _{dis} Disable time	C _L = 5 pF See Note 3		15	40		15	35	ns

[†]For conditions shown as MIN or MAX, use appropriate value specified under recommended operating conditions.

[‡]All typical values are at V_{CC} = 5 V, T_A = 25 °C.

[§]Not more than one output should be shorted at a time, and duration of the short circuit should not exceed one second.

NOTE 3: Load circuits and voltage waveforms are shown in Section 1.

4
PROMS

TBP28SA46
4096 BITS (512 WORDS BY 8 BITS)
STANDARD PROGRAMMABLE READ-ONLY MEMORIES WITH OPEN-COLLECTOR OUTPUTS

logic symbol

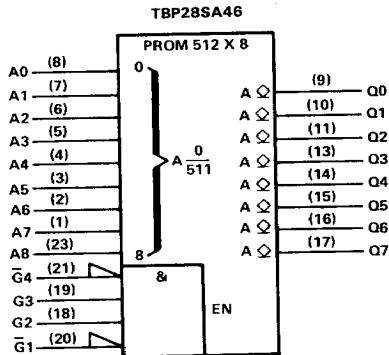

pin assignment

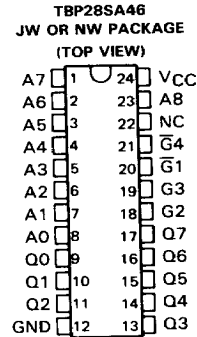

recommended operating conditions

PARAMETER	MJW			JW OR NW			UNIT
	MIN	NOM	MAX	MIN	NOM	MAX	
V _{CC} Supply voltage	4.5	5	5.5	4.75	5	5.25	V
V _{IH} High-level input voltage	2			2			V
V _{IL} Low-level input voltage			0.8			0.8	V
V _{OH} High-level output voltage			5.5			5.5	V
I _{OL} Low-level output current			16			16	mA
T _A Operating free-air temperature range	-55		125	0		70	°C

electrical characteristics over recommended operating free-air temperature range (unless otherwise noted)

PARAMETER	TEST CONDITIONS [†]	MJW			JW OR NW			UNIT	
		MIN	TYP [‡]	MAX	MIN	TYP [‡]	MAX		
V _{IK}	V _{CC} = MIN, I _I = -18 mA			-1.2			-1.2	V	
I _{OH}	V _{CC} = MIN, V _{OH} = 2.4 V			0.05			0.05	mA	
I _{OH}	V _{CC} = MIN, V _{OH} = 5.5 V			0.1			0.1	mA	
V _{OL}	V _{CC} = MIN, I _{OL} = 16 mA			0.5			0.5	V	
I _I	V _{CC} = MAX, V _I = 5.5 V			1			1	mA	
I _{IH}	V _{CC} = MAX, V _I = 2.7 V			25			25	μA	
I _{IL}	V _{CC} = MAX, V _I = 0.5 V			-0.25			-0.25	mA	
I _{CC}	V _{CC} = MAX			100		135	100	135	mA

switching characteristics over recommended ranges of T_A and V_{CC} (unless otherwise noted)

PARAMETER	TEST CONDITIONS	MJW			JW OR NW			UNIT		
		MIN	TYP [‡]	MAX	MIN	TYP [‡]	MAX			
t _{a(A)} Access time from address	C _L = 30 pF			35		75		35	65	ns
t _{a(S)} Access time from chip select (enable time)	R _{L1} = 300 Ω			20		45		20	35	ns
t _{PLH} Propagation delay time low-to-high-level output from chip select	R _{L2} = 600 Ω See Note 3			15		40		15	35	ns

[†]For conditions shown as MIN or MAX, use appropriate value specified under recommended operating conditions.

[‡]All typical values are at V_{CC} = 5 V, T_A = 25 °C.

NOTE 3: Load circuits and voltage waveforms are shown in Section 1.

4 PROMS

TBP24S41
4096 BITS (1024 WORDS BY 4 BITS)
STANDARD PROGRAMMABLE READ-ONLY MEMORIES WITH 3-STATE OUTPUTS

logic symbol

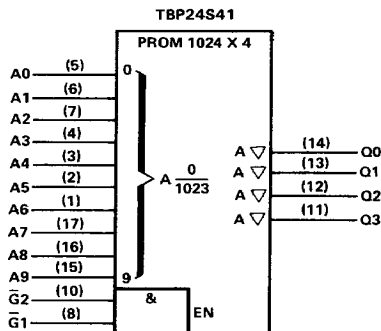

pin assignment

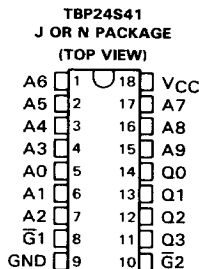

recommended operating conditions

PARAMETER	MJ			J OR N			UNIT
	MIN	NOM	MAX	MIN	NOM	MAX	
V _{CC} Supply voltage	4.5	5	5.5	4.75	5	5.25	V
V _{IH} High-level input voltage	2			2			V
V _{IL} Low-level input voltage			0.8			0.8	V
I _{OH} High-level output current			-2			-3.2	mA
I _{OL} Low-level output current			16			16	mA
T _A Operating free-air temperature range	-55		125	0		70	°C

electrical characteristics over recommended operating free-air temperature range (unless otherwise noted)

PARAMETER	TEST CONDITIONS [†]	MJ			J OR N			UNIT
		MIN	TYP [‡]	MAX	MIN	TYP [‡]	MAX	
V _{IK}	V _{CC} = MIN, I _I = -18 mA			-1.2			-1.2	V
V _{OH}	V _{CC} = MIN, I _{OH} = MAX	2.4	3.1		2.4	3.1		V
V _{OL}	V _{CC} = MIN, I _{OL} = 16 mA			0.5			0.5	V
I _{OZH}	V _{CC} = MAX, V _O = 2.4 V			50			50	μA
I _{OZL}	V _{CC} = MAX, V _O = 0.5 V			-50			-50	μA
I _I	V _{CC} = MAX, V _I = 5.5 V			1			1	mA
I _{IH}	V _{CC} = MAX, V _I = 2.7 V			25			25	μA
I _{IL}	V _{CC} = MAX, V _I = 0.5 V			-0.25			-0.25	mA
I _{OS} [§]	V _{CC} = MAX	-15		-100	-20		-100	mA
I _{CC}	V _{CC} = MAX		95	140		95	140	mA

switching characteristics over recommended ranges of T_A and V_{CC} (unless otherwise noted)

PARAMETER	TEST CONDITIONS	MJ			J OR N			UNIT
		MIN	TYP [‡]	MAX	MIN	TYP [‡]	MAX	
t _{a(A)} Access time from address	C _L = 30 pF	40		75	40		60	ns
t _{a(S)} Access time from chip select (enable time)	See Note 3	20		40	20		30	ns
t _{dis} Disable time	C _L = 5 pF See Note 3	20		40	20		30	ns

[†]For conditions shown as MIN or MAX, use appropriate value specified under recommended operating conditions.

[‡]All typical values are at V_{CC} = 5 V, T_A = 25 °C.

[§]Not more than one output should be shorted at a time, and duration of the short circuit should not exceed one second.

NOTE 3: Load circuits and voltage waveforms are shown in Section 1.

4

PROMS

TBP24SA41
4096 BITS (1024 WORDS BY 4 BITS)
STANDARD PROGRAMMABLE READ-ONLY MEMORIES WITH OPEN-COLLECTOR OUTPUTS

logic symbol

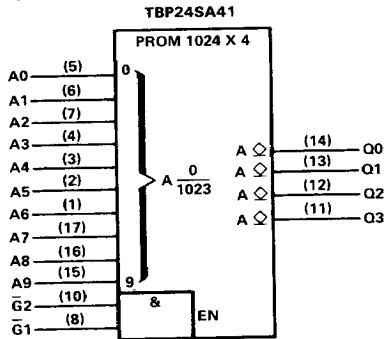

pin assignment

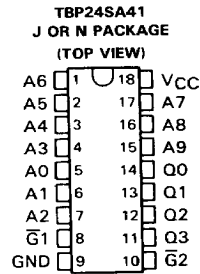

recommended operating conditions

PARAMETER	MJ			J OR N			UNIT
	MIN	NOM	MAX	MIN	NOM	MAX	
V _{CC} Supply voltage	4.5	5	5.5	4.75	5	5.25	V
V _{IH} High-level input voltage	2			2			V
V _{IL} Low-level input voltage	0.8			0.8			V
V _{OH} High-level output voltage	5.5			5.5			V
I _{OL} Low-level output current	16			16			mA
T _A Operating free-air temperature range	-55			125			°C

4

PROMS

electrical characteristics over recommended operating free-air temperature range (unless otherwise noted)

PARAMETER	TEST CONDITIONS [†]	MJ		J OR N		UNIT
		MIN	TYP [‡]	MAX	MIN	
V _{IK}	V _{CC} = MIN, I _I = -18 mA	-1.2		-1.2		V
I _{OH}	V _{CC} = MIN, V _{OH} = 2.4 V	0.05		0.05		mA
		0.1		0.1		
V _{OL}	V _{CC} = MIN, I _{OL} = 16 mA	0.5		0.5		V
I _I	V _{CC} = MAX, V _I = 5.5 V	1		1		mA
I _{IH}	V _{CC} = MAX, V _I = 2.7 V	25		25		μA
I _{IL}	V _{CC} = MAX, V _I = 0.5 V	-0.25		-0.25		mA
I _{CC}	V _{CC} = MAX	95	140	95	140	mA

switching characteristics over recommended ranges of T_A and V_{CC} (unless otherwise noted)

PARAMETER	TEST CONDITIONS	MJ			J OR N			UNIT
		MIN	TYP [‡]	MAX	MIN	TYP [‡]	MAX	
t _{a(A)} Access time from address	C _L = 30 pF R _{L1} = 300 Ω R _{L2} = 600 Ω See Note 3	40	75	40	60	60	ns	
t _{a(S)} Access time from chip select (enable time)		20	40	20	30	30	ns	
t _{PLH} Propagation delay time low-to-high-level output from chip select		20	40	20	30	30	ns	

[†]For conditions shown as MIN or MAX, use appropriate value specified under recommended operating conditions.

[‡]All typical values are at V_{CC} = 5 V, T_A = 25°C.

NOTE 3: Load circuits and voltage waveforms are shown in Section 1.

TBP24S81
8192 BITS (2048 WORDS BY 4 BITS)
STANDARD PROGRAMMABLE READ-ONLY MEMORIES WITH 3-STATE OUTPUTS

logic symbol

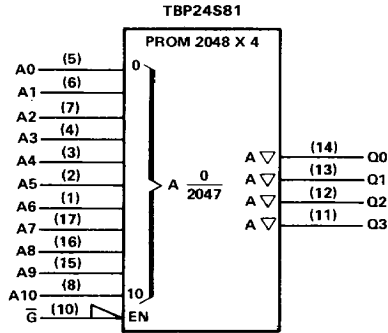

pin assignment

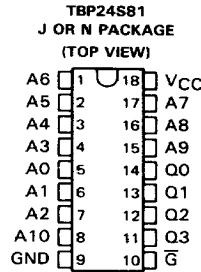

recommended operating conditions

PARAMETER	MJ			J OR N			UNIT
	MIN	NOM	MAX	MIN	NOM	MAX	
V _{CC} Supply voltage	4.5	5	5.5	4.75	5	5.25	V
V _{IH} High-level input voltage	2			2			V
V _{IL} Low-level input voltage	0.8			0.8			V
I _{OH} High-level output current	-2			-3.2			mA
I _{OL} Low-level output current	16			16			mA
T _A Operating free-air temperature range	-55 125			0 70			°C

electrical characteristics over recommended operating free-air temperature range (unless otherwise noted)

PARAMETER	TEST CONDITIONS [†]	MJ		J OR N		UNIT
		MIN	TYP [‡]	MAX	MIN	
V _{IK}	V _{CC} = MIN, I _I = -18 mA	-1.2		-1.2		V
V _{OH}	V _{CC} = MIN, I _{OH} = MAX	2.4	3.1	2.4 3.1		V
V _{OL}	V _{CC} = MIN, I _{OL} = 16 mA	0.5		0.5		V
I _{OZH}	V _{CC} = MAX, V _O = 2.4 V	50		50		μA
I _{OZL}	V _{CC} = MAX, V _O = 0.5 V	-50		-50		μA
I _I	V _{CC} = MAX, V _I = 5.5 V	1		1		mA
I _{IH}	V _{CC} = MAX, V _I = 2.7 V	25		25		μA
I _{IL}	V _{CC} = MAX, V _I = 0.5 V	-0.25		-0.25		mA
I _{OS} [§]	V _{CC} = MAX	-15	-100	-20	-100	mA
I _{CC}	V _{CC} = MAX	125	175	125	175	mA

switching characteristics over recommended ranges of T_A and V_{CC} (unless otherwise noted)

PARAMETER	TEST CONDITIONS	MJ		J OR N		UNIT
		MIN	TYP [‡]	MAX	MIN	
t _{a(A)} Access time from address	C _L = 30 pF	45	85	45	70	ns
t _{a(S)} Access time from chip select (enable time)	See Note 3	20	50	20	40	ns
t _{dis} Disable time	C _L = 5 pF See Note 3	20	50	20	40	ns

[†]For conditions shown as MIN or MAX, use appropriate value specified under recommended operating conditions.

[‡]All typical values are at V_{CC} = 5 V, T_A = 25°C.

[§]Not more than one output should be shorted at a time, and duration of the short circuit should not exceed one second.

NOTE 3: Load circuits and voltage waveforms are shown in Section 1.

4

PROMS

TBP24SA81
8192 BITS (2048 WORDS BY 4 BITS)
STANDARD PROGRAMMABLE READ-ONLY MEMORIES WITH OPEN-COLLECTOR OUTPUTS

logic symbol

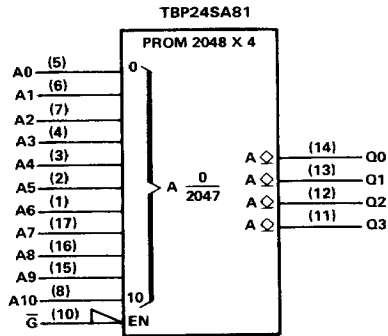

pin assignment

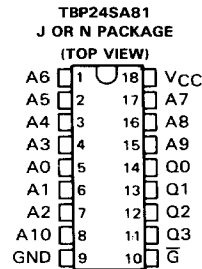

recommended operating conditions

PARAMETER	MJ			J OR N			UNIT
	MIN	NOM	MAX	MIN	NOM	MAX	
V _{CC} Supply voltage	4.5	5	5.5	4.75	5	5.25	V
V _{IH} High-level input voltage	2			2			V
V _{IL} Low-level input voltage	0.8			0.8			V
V _{OH} High-level output voltage	5.5			5.5			V
I _{OL} Low-level output current	16			16			mA
T _A Operating free-air temperature range	-55 125			0 70			°C

4

PROMS

electrical characteristics over recommended operating free-air temperature range (unless otherwise noted)

PARAMETER	TEST CONDITIONS [†]	MJ		J OR N		UNIT
		MIN	TYP [‡]	MAX	MIN	
V _{IK}	V _{CC} = MIN, I _I = -18 mA	-1.2		-1.2		V
I _{OH}	V _{CC} = MIN, V _{OH} = 2.4 V	0.05		0.05		VmA
		0.1		0.1		
V _{OL}	V _{CC} = MIN, I _{OL} = 16 mA	0.5		0.5		V
I _I	V _{CC} = MAX, V _I = 5.5 V	1		1		mA
I _{IH}	V _{CC} = MAX, V _I = 2.7 V	25		25		μA
I _{IL}	V _{CC} = MAX, V _I = 0.5 V	-0.25		-0.25		mA
I _{CC}	V _{CC} = MAX	125	175	125	175	mA

switching characteristics over recommended ranges of T_A and V_{CC} (unless otherwise noted)

PARAMETER	TEST CONDITIONS	MJ		J OR N		UNIT
		MIN	TYP [‡]	MAX	MIN	
t _{a(A)} Access time from address	C _L = 30 pF	45	95	45	70	ns
t _{a(S)} Access time from chip select (enable time)	R _{L1} = 300 Ω	20	50	20	40	ns
	R _{L2} = 600 Ω	20 50		20 40		
t _{PLH} Propagation delay time low-to-high-level output from chip select	See Note 3	20 50		20 40		ns

[†]For conditions shown as MIN or MAX, use appropriate value specified under recommended operating conditions.

[‡]All typical values are at V_{CC} = 5 V, T_A = 25°C.

NOTE 3: Load circuits and voltage waveforms are shown in Section 1.

TBP28S86A
8192 BITS (1024 WORDS BY 8 BITS)
STANDARD PROGRAMMABLE READ-ONLY MEMORIES WITH 3-STATE OUTPUTS

logic symbol

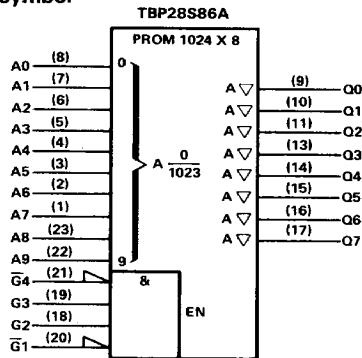

pin assignment

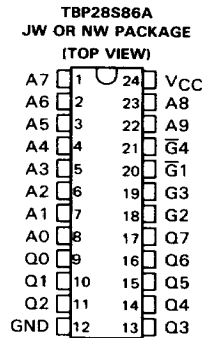

recommended operating conditions

PARAMETER	MJW			JW OR NW			UNIT
	MIN	NOM	MAX	MIN	NOM	MAX	
V _{CC} Supply voltage	4.5	5	5.5	4.75	5	5.25	V
V _{IH} High-level input voltage	2			2			V
V _{IL} Low-level input voltage			0.8			0.8	V
I _{OH} High-level output current			-2			-3.2	mA
I _{OL} Low-level output current			12			12	mA
T _A Operating free-air temperature range	-55		125	0		70	°C

electrical characteristics over recommended operating free-air temperature range (unless otherwise noted)

PARAMETER	TEST CONDITIONS [†]	MJW			JW OR NW			UNIT
		MIN	TYP [‡]	MAX	MIN	TYP [‡]	MAX	
V _{IK}	V _{CC} = MIN, I _I = -18 mA			-1.2			-1.2	V
V _{OH}	V _{CC} = MIN, I _{OH} = MAX	2.4	3.1		2.4	3.1		V
V _{OL}	V _{CC} = MIN, I _{OL} = 12 mA			0.5			0.5	V
I _{OHZ}	V _{CC} = MAX, V _O = 2.4 V			50			50	μA
I _{OLZ}	V _{CC} = MAX, V _O = 0.5 V			-50			-50	μA
I _I	V _{CC} = MAX, V _I = 5.5 V			1			1	mA
I _{IH}	V _{CC} = MAX, V _I = 2.7 V			25			25	μA
I _{IL}	V _{CC} = MAX, V _I = 0.5 V			-0.25			-0.25	mA
I _{OS} [§]	V _{CC} = MAX	-15		-100	-20		-100	mA
I _{CC}	V _{CC} = MAX		110	170		110	165	mA

switching characteristics over recommended ranges of T_A and V_{CC} (unless otherwise noted)

PARAMETER	TEST CONDITIONS	MJW			JW OR NW			UNIT	
		MIN	TYP [‡]	MAX	MIN	TYP [‡]	MAX		
t _{aA}	Access time from address		C _L = 30 pF	35	80		35	65	ns
t _{a(S)}	Access time from chip select (enable time)		See Note 3	20	50		20	40	ns
t _{dis}	Disable time		C _L = 5 pF See Note 3	15	40		15	35	ns

[†]For conditions shown as MIN or MAX, use appropriate value specified under recommended operating conditions.

[‡]All typical values are at V_{CC} = 5 V, T_A = 25 °C.

[§]Not more than one output should be shorted at a time, and duration of the short circuit should not exceed one second.

NOTE 3: Load circuits and voltage waveforms are shown in Section 1.

4

PROMS

TBP28SA86A
8192 BITS (1024 WORDS BY 8 BITS)
STANDARD PROGRAMMABLE READ-ONLY MEMORIES WITH OPEN-COLLECTOR OUTPUTS

logic symbol

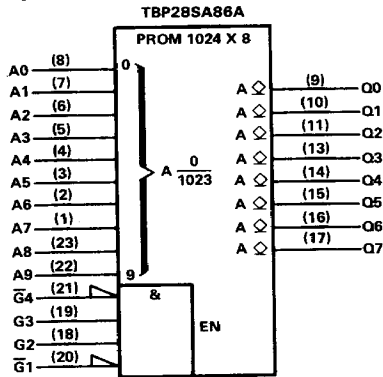

pin assignment

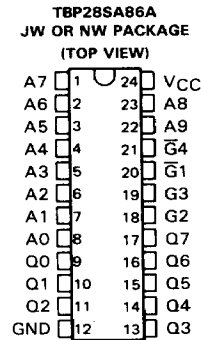

recommended operating conditions

PARAMETER	MJW			JW OR NW			UNIT		
	MIN	NOM	MAX	MIN	NOM	MAX			
V _{CC} Supply voltage	4.5	5	5.5	4.75	5	5.25	V		
V _{IH} High-level input voltage	2			2			V		
V _{IL} Low-level input voltage	0.8			0.8			V		
V _{OH} High-level output voltage	5.5			5.5			V		
I _{OL} Low-level output current	12			12			mA		
T _A Operating free-air temperature range	-55			125			0	70	°C

electrical characteristics over recommended operating free-air temperature range (unless otherwise noted)

PARAMETER	TEST CONDITIONS [†]	MJW			JW OR NW			UNIT
		MIN	TYP [‡]	MAX	MIN	TYP [‡]	MAX	
V _{IK}	V _{CC} = MIN, I _I = -18 mA	-1.2			-1.2			V
I _{OH}	V _{CC} = MIN, V _{OH} = 2.4 V	0.05			0.05			mA
		0.1			0.1			mA
I _{OL}	V _{CC} = MIN, I _{OL} = 12 mA	0.5			0.5			V
		1			1			mA
I _I	V _{CC} = MAX, V _I = 5.5 V	25			25			μA
I _{IH}	V _{CC} = MAX, V _I = 2.7 V	-0.25			-0.25			mA
I _{IL}	V _{CC} = MAX, V _I = 0.5 V	125			175			mA
I _{CC}	V _{CC} = MAX	125			175			mA

switching characteristics over recommended ranges of T_A and V_{CC} (unless otherwise noted)

PARAMETER	TEST CONDITIONS	MJW			JW OR NW			UNIT
		MIN	TYP [‡]	MAX	MIN	TYP [‡]	MAX	
t _{a(A)} Access time from address	C _L = 30 pF R _{L1} = 300 Ω R _{L2} = 600 Ω See Note 3	35			80			ns
t _{a(S)} Access time from chip select (enable time)		20			50			ns
t _{PLH} Propagation delay time low-to-high-level output from chip select		15			40			ns

[†]For conditions shown as MIN or MAX, use appropriate value specified under recommended operating conditions.

[‡]All typical values are at V_{CC} = 5 V, T_A = 25 °C.

NOTE 3: Load circuits and voltage waveforms are shown in Section 1.

4
 PROMS

TBP28S2708A
8192 BITS (1024 WORDS BY 8 BITS)
STANDARD PROGRAMMABLE READ-ONLY MEMORIES WITH 3-STATE OUTPUTS

logic symbol

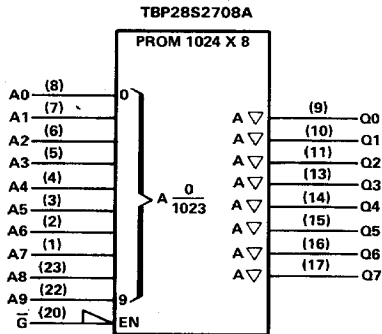

pin assignment

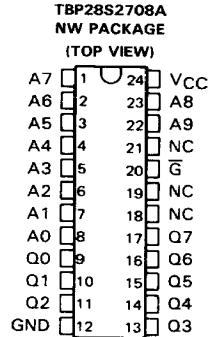

recommended operating conditions

PARAMETER	NW			UNIT
	MIN	NOM	MAX	
V _{CC} Supply voltage	4.75	5	5.25	V
V _{IH} High-level input voltage	2			V
V _{IL} Low-level input voltage				0.8
I _{OH} High-level output current				-3.2
I _{OL} Low-level output current				12
T _A Operating free-air temperature range	0	70		°C

electrical characteristics over recommended operating free-air temperature range (unless otherwise noted)

PARAMETER	TEST CONDITIONS	NW			UNIT
		MIN	TYP [†]	MAX	
V _{IK}	V _{CC} = 4.75, I _I = -18 mA	-1.2			V
V _{OH}	V _{CC} = 4.75, I _{OH} = -3.2 mA	2.4	3.1		V
V _{OL}	V _{CC} = 4.75, I _{OL} = 12 mA	0.5			V
I _{OZH}	V _{CC} = 5.25, V _O = 2.4 V	50			μA
I _{OZL}	V _{CC} = 5.25, V _O = 0.5 V	-50			μA
I _I	V _{CC} = 5.25, V _I = 5.5 V	1			mA
I _{IH}	V _{CC} = 5.25, V _I = 2.7 V	25			μA
I _{IL}	V _{CC} = 5.25, V _I = 0.5 V	-0.25			mA
I _{OS} [‡]	V _{CC} = 5.25	-20	-100		mA
I _{CC}	V _{CC} = 5.25	110	165		mA

switching characteristics over recommended ranges of T_A and V_{CC} (unless otherwise noted)

PARAMETER	TEST CONDITIONS	NW			UNIT
		MIN	TYP [†]	MAX	
t _{a(A)} Access time from address	C _L = 30 pF	45	70		ns
t _{a(S)} Access time from chip select (enable time)	See Note 3	20	40		ns
t _{dis} Disable time	C _L = 5 pF See Note 3	20	40		ns

[†]All typical values are at V_{CC} = 5 V, T_A = 25°C.

[‡]Not more than one output should be shorted at a time, and duration of the short circuit should not exceed one second.

NOTE 3: Load circuits and voltage waveforms are shown in Section 1.

4

PROMS



POST OFFICE BOX 225012 • DALLAS, TEXAS 75265

TBP28S166
16,384 BITS (2084 WORDS BY 8 BITS)
STANDARD PROGRAMMABLE READ-ONLY MEMORIES WITH 3-STATE OUTPUTS

logic symbol

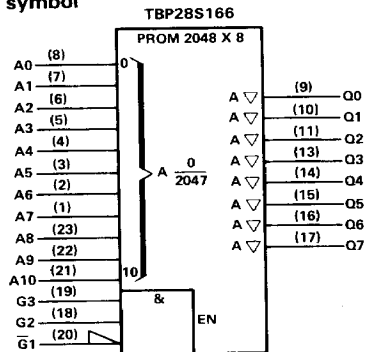

pin assignment

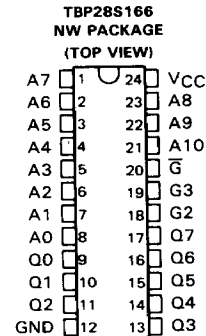

recommended operating conditions

PARAMETER	NW			UNIT
	MIN	NOM	MAX	
V _{CC} Supply voltage	4.75	5	5.25	V
V _{IH} High-level input voltage	2			V
V _{IL} Low-level input voltage			0.8	V
I _{OH} High-level output current			-3.2	mA
I _{OL} Low-level output current			16	mA
T _A Operating free-air temperature range	0		70	°C

4

PROMS

electrical characteristics over recommended operating free-air temperature range (unless otherwise noted)

PARAMETER	TEST CONDITIONS	NW			UNIT
		MIN	TYP†	MAX	
V _{IK}	V _{CC} = 4.75, I _I = -18 mA			-1.2	V
V _{OH}	V _{CC} = 4.75, I _{OH} = -3.2 mA	2.4	3.1		V
V _{OL}	V _{CC} = 4.75, I _{OL} = 16 mA			0.5	V
I _{OZH}	V _{CC} = 5.25, V _O = 2.4 V			50	μA
I _{OZL}	V _{CC} = 5.25, V _O = 0.5 V			-50	μA
I _I	V _{CC} = 5.25, V _I = 5.5 V			1	mA
I _{IH}	V _{CC} = 5.25, V _I = 2.7 V			25	μA
I _{IL}	V _{CC} = 5.25, V _I = 0.5 V			-0.25	mA
I _{OS} ‡	V _{CC} = 5.25	-20		-100	mA
I _{CC}	V _{CC} = 5.25		130	175	mA

switching characteristics over recommended ranges of T_A and V_{CC} (unless otherwise noted)

PARAMETER	TEST CONDITIONS	NW			UNIT
		MIN	TYP†	MAX	
t _a (A) Access time from address	C _L = 30 pF		35	75	ns
t _a (S) Access time from chip select (enable time)	See Note 3		15	40	ns
t _{dis} Disable time	C _L = 5 pF See Note 3		15	40	ns

†All typical values are at V_{CC} = 5 V, T_A = 25°C.

‡Not more than one output should be shorted at a time, and duration of the short circuit should not exceed one second.

NOTE 3: Load circuits and voltage waveforms are shown in Section 1.

TBP28L22
2048 BITS (256 WORDS BY 8 BITS)
LOW-POWER PROGRAMMABLE READ-ONLY MEMORIES WITH 3-STATE OUTPUTS

logic symbol

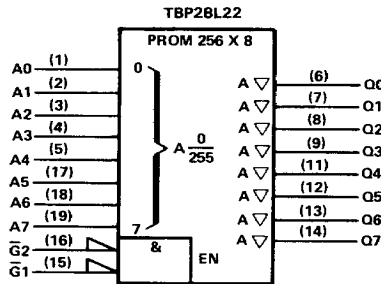

pin assignment

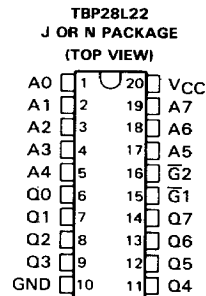

recommended operating conditions

PARAMETER	MJ			J OR N			UNIT
	MIN	NOM	MAX	MIN	NOM	MAX	
V _{CC} Supply voltage	4.5	5	5.5	4.75	5	5.25	V
V _{IH} High-level input voltage	2			2			V
V _{IL} Low-level input voltage	0.8			0.8			V
I _{OH} High-level output current	-2			-6.5			mA
I _{OL} Low-level output current	16			16			mA
T _A Operating free-air temperature range	-55			125			°C

electrical characteristics over recommended operating free-air temperature range (unless otherwise noted)

PARAMETER	TEST CONDITIONS [†]	MJ			J OR N			UNIT
		MIN	TYP [‡]	MAX	MIN	TYP [‡]	MAX	
V _{IK}	V _{CC} = MIN, I _I = -18 mA	-1.2			-1.2			V
V _{OH}	V _{CC} = MIN, I _{OH} = MAX	2.4	3.1		2.4	3.1	V	
V _{OL}	V _{CC} = MIN, I _{OL} = 16 mA	0.5			0.5			V
I _{OZH}	V _{CC} = MAX, V _O = 2.4 V	50			50			µA
I _{OZL}	V _{CC} = MAX, V _O = 0.5 V	-50			-50			µA
I _I	V _{CC} = MAX, V _I = 5.5 V	1			1			mA
I _{IH}	V _{CC} = MAX, V _I = 2.7 V	25			25			µA
I _{IL}	V _{CC} = MAX, V _I = 0.5 V	-0.25			-0.25			mA
I _{OS} [§]	V _{CC} = MAX	-25		-100	-30		-100	mA
I _{CC}	V _{CC} = MAX	75			100			mA

switching characteristics over recommended ranges of T_A and V_{CC} (unless otherwise noted)

PARAMETER	TEST CONDITIONS	MJ			J OR N			UNIT
		MIN	TYP [‡]	MAX	MIN	TYP [‡]	MAX	
t _{aA}	Access time from address C _L = 30 pF	45	75		45	70	ns	
t _{a(S)}	Access time from chip select (enable time) See Note 3	20	40		20	35	ns	
t _{dis}	Disable time C _L = 5 pF See Note 3	15	35		15	30	ns	

[†]For conditions shown as MIN or MAX, use appropriate value specified under recommended operating conditions.

[‡]All typical values are at V_{CC} = 5 V, T_A = 25 °C.

[§]Not more than one output should be shorted at a time, and duration of the short circuit should not exceed one second.

NOTE 3: Load circuits and voltage waveforms are shown in Section 1.

4

PROMS

TBP28LA22
2048 BITS (256 WORDS BY 8 BITS)
LOW-POWER PROGRAMMABLE READ-ONLY MEMORIES WITH OPEN-COLLECTOR OUTPUTS

logic symbol

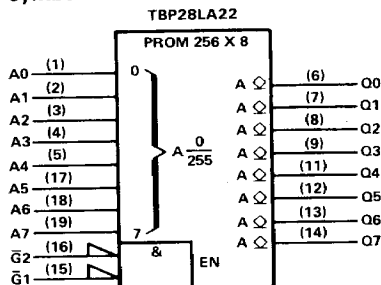

pin assignment

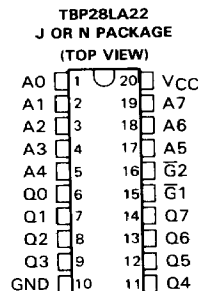

recommended operating conditions

PARAMETER	MJ			J OR N			UNIT
	MIN	NOM	MAX	MIN	NOM	MAX	
V _{CC} Supply voltage	4.5	5	5.5	4.75	5	5.25	V
V _{IH} High-level input voltage	2			2			V
V _{IL} Low-level input voltage				0.8			V
V _{OH} High-level output voltage				5.5			V
I _{OL} Low-level output current				16			mA
T _A Operating free-air temperature range	-55		125	0		70	°C

4

PROMS

electrical characteristics over recommended operating free-air temperature range (unless otherwise noted)

PARAMETER	TEST CONDITIONS†	MJ			J OR N			UNIT
		MIN	TYP‡	MAX	MIN	TYP‡	MAX	
V _{IK}	V _{CC} = MIN, I _I = -18 mA	-1.2			-1.2			V
I _{OH}	V _{CC} = MIN, V _{OH} = 2.4 V	0.05			0.05			mA
		0.1			0.1			mA
V _{OL}	V _{CC} = MIN, I _{OL} = 16 mA	0.5			0.5			V
I _I	V _{CC} = MAX, V _I = 5.5 V	1			1			mA
I _{IH}	V _{CC} = MAX, V _I = 2.7 V	25			25			μA
I _{IL}	V _{CC} = MAX, V _I = 0.5 V	-0.25			-0.25			mA
I _{CC}	V _{CC} = MAX	75		100	75		100	mA

switching characteristics over recommended ranges of T_A and V_{CC} (unless otherwise noted)

PARAMETER	TEST CONDITIONS	MJ			J OR N			UNIT
		MIN	TYP‡	MAX	MIN	TYP‡	MAX	
t _{aA} Access time from address	C _L = 30 pF	40		80	45		75	ns
t _{aS} Access time from chip select (enable time)	RL1 = 300 Ω	20		40	20		35	ns
t _{PLH} Propagation delay time low-to-high-level output from chip select	RL2 = 600 Ω See Note 3	15		35	15		30	ns

†For conditions shown as MIN or MAX, use appropriate value specified under recommended operating conditions.

‡All typical values are at V_{CC} = 5 V, T_A = 25°C.

NOTE 3: Load circuits and voltage waveforms are shown in Section 1.

TBP28L42
4096 BITS (512 WORDS BY 8 BITS)
LOW-POWER PROGRAMMABLE READ-ONLY MEMORIES WITH 3-STATE OUTPUTS

logic symbol

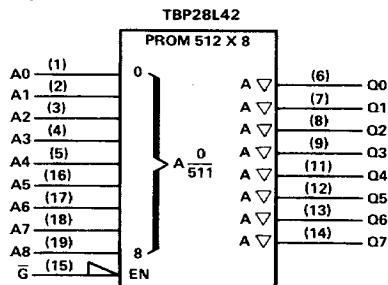

pin assignment

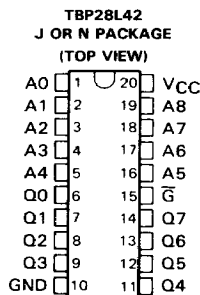

recommended operating conditions

PARAMETER	MJ			J OR N			UNIT
	MIN	NOM	MAX	MIN	NOM	MAX	
V _{CC} Supply voltage	4.5	5	5.5	4.75	5	5.25	V
V _{IH} High-level input voltage	2			2			V
V _{IL} Low-level input voltage			0.8			0.8	V
I _{OH} High-level output current			-1			-1.6	mA
I _{OL} Low-level output current			8			8	mA
T _A Operating free-air temperature range	-55		125	0		70	°C

electrical characteristics over recommended operating free-air temperature range (unless otherwise noted)

PARAMETER	TEST CONDITIONS [†]	MJ		J OR N		UNIT		
		MIN	TYP [‡]	MAX	MIN		TYP [‡]	MAX
V _{IK}	V _{CC} = MIN, I _I = -18 mA			-1.2		-1.2	V	
V _{OH}	V _{CC} = MIN, I _{OH} = MAX	2.4	3.1		2.4	3.1	V	
V _{OL}	V _{CC} = MIN, I _{OL} = 8 mA			0.5		0.5	V	
I _{OZH}	V _{CC} = MAX, V _O = 2.4 V			50		50	µA	
I _{OZL}	V _{CC} = MAX, V _O = 0.5 V			-50		-50	µA	
I _I	V _{CC} = MAX, V _I = 5.5 V			1		1	mA	
I _{IH}	V _{CC} = MAX, V _I = 2.7 V			25		25	µA	
I _{IL}	V _{CC} = MAX, V _I = 0.5 V			-0.25		-0.25	mA	
I _{OS} [§]	V _{CC} = MAX	-10		-100	-10	-100	mA	
I _{CC}	V _{CC} = MAX		50	85		50	85	mA

switching characteristics over recommended ranges of T_A and V_{CC} (unless otherwise noted)

PARAMETER	TEST CONDITIONS	MJ		J OR N		UNIT		
		MIN	TYP [‡]	MAX	MIN		TYP [‡]	MAX
t _{a(A)} Access time from address	C _L = 30 pF		55	110		55	95	ns
t _{a(S)} Access time from chip select (enable time)	See Note 3		25	60		25	60	ns
t _{dis} Disable time	C _L = 5 pF See Note 3		25	50		25	40	ns

[†]For conditions shown as MIN or MAX, use appropriate value specified under recommended operating conditions.

[‡]All typical values are at V_{CC} = 5 V, T_A = 25°C.

[§]Not more than one output should be shorted at a time, and duration of the short circuit should not exceed one second.

NOTE 3: Load circuits and voltage waveforms are shown in Section 1.

4

PROMS

TBP28L46
4096 BITS (512 WORDS BY 8 BITS)
LOW-POWER PROGRAMMABLE READ-ONLY MEMORIES WITH 3-STATE OUTPUTS

logic symbol

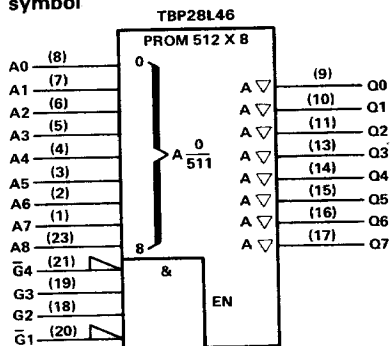

pin assignment

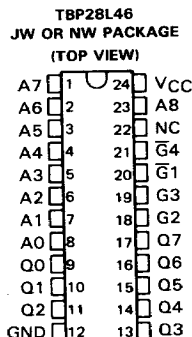

recommended operating conditions

PARAMETER	MJW			JW OR NW			UNIT
	MIN	NOM	MAX	MIN	NOM	MAX	
V _{CC} Supply voltage	4.5	5	5.5	4.75	5	5.25	V
V _{IH} High-level input voltage	2			2			V
V _{IL} Low-level input voltage			0.8			0.8	V
I _{OH} High-level output current			-1			-1.6	mA
I _{OL} Low-level output current			8			8	mA
T _A Operating free-air temperature range	-55		125	0		70	°C

4

electrical characteristics over recommended operating free-air temperature range (unless otherwise noted)

PROMS

PARAMETER	TEST CONDITIONS [†]	MJW			JW OR NW			UNIT
		MIN	TYP [‡]	MAX	MIN	TYP [‡]	MAX	
V _{IK}	V _{CC} = MIN, I _I = -18 mA			-1.2			-1.2	V
V _{OH}	V _{CC} = MIN, I _{OH} = MAX	2.4	3.1		2.4	3.1		V
V _{OL}	V _{CC} = MIN, I _{OL} = 8 mA			0.5			0.5	V
I _{OZH}	V _{CC} = MAX, V _O = 2.4 V			50			50	μA
I _{OZL}	V _{CC} = MAX, V _O = 0.5 V			-50			-50	μA
I _I	V _{CC} = MAX, V _I = 5.5 V			1			1	mA
I _{IH}	V _{CC} = MAX, V _I = 2.7 V			25			25	μA
I _{IHL}	V _{CC} = MAX, V _I = 0.5 V			-0.25			-0.25	mA
I _{OS} [§]	V _{CC} = MAX	-10		-100	-10		-100	mA
I _{CC}	V _{CC} = MAX		50	85		50	85	mA

switching characteristics over recommended ranges of T_A and V_{CC} (unless otherwise noted)

PARAMETER	TEST CONDITIONS	MJW			JW OR NW			UNIT
		MIN	TYP [‡]	MAX	MIN	TYP [‡]	MAX	
t _{a(A)} Access time from address	C _L = 30 pF	55	110		55	95		ns
t _{a(S)} Access time from chip select (enable time)	See Note 3		25	60		25	60	ns
t _{dis} Disable time	C _L = 5 pF See Note 3		25	50		25	40	ns

[†]For conditions shown as MIN or MAX, use appropriate value specified under recommended operating conditions.

[‡]All typical values are at V_{CC} = 5 V, T_A = 25°C.

[§]Not more than one output should be shorted at a time, and duration of the short circuit should not exceed one second.

NOTE 3: Load circuits and voltage waveforms are shown in Section 1.

TBP28L86A
8192 BITS (1024 WORDS BY 8 BITS)
LOW-POWER PROGRAMMABLE READ-ONLY MEMORIES WITH 3-STATE OUTPUTS

logic symbol

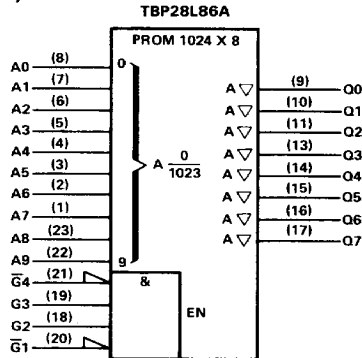

pin assignment

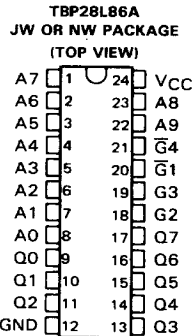

recommended operating conditions

PARAMETER	MJW			JW OR NW			UNIT
	MIN	NOM	MAX	MIN	NOM	MAX	
V _{CC} Supply voltage	4.5	5	5.5	4.75	5	5.25	V
V _{IH} High-level input voltage	2			2			V
V _{IL} Low-level input voltage			0.8			0.8	V
I _{OH} High-level output current			-1			-1.6	mA
I _{OL} Low-level output current			8			8	mA
T _A Operating free-air temperature range	-55		125	0		70	°C

electrical characteristics over recommended operating free-air temperature range (unless otherwise noted)

PARAMETER	TEST CONDITIONS [†]	MJW			JW OR NW			UNIT
		MIN	TYP [‡]	MAX	MIN	TYP [‡]	MAX	
V _{IK}	V _{CC} = MIN, I _I = -18 mA			-1.2			-1.2	V
V _{OH}	V _{CC} = MIN, I _{OH} = MAX	2.4	3.1		2.4	3.1		V
V _{OL}	V _{CC} = MIN, I _{OL} = 8 mA			0.5			0.5	V
I _{OZH}	V _{CC} = MAX, V _O = 2.4 V			50			50	μA
I _{OZL}	V _{CC} = MAX, V _O = 0.5 V			-50			-50	μA
I _I	V _{CC} = MAX, V _I = 5.5 V			1			1	mA
I _{IH}	V _{CC} = MAX, V _I = 2.7 V			25			25	μA
I _{IL}	V _{CC} = MAX, V _I = 0.5 V			-0.25			-0.25	mA
I _{OS} [§]	V _{CC} = MAX			-10			-10	mA
I _{CC}	V _{CC} = MAX			55			55	mA

switching characteristics over recommended ranges of T_A and V_{CC} (unless otherwise noted)

PARAMETER	TEST CONDITIONS	MJW		JW OR NW		UNIT
		MIN	TYP [‡]	MIN	TYP [‡]	
t _{g(A)} Access time from address	C _L = 30 pF	65	200	65	110	ns
t _{a(S)} Access time from chip select (enable time)	See Note 3	40	125	40	80	ns
t _{dis} Disable time	C _L = 5 pF See Note 3	25	100	25	60	ns

[†]For conditions shown as MIN or MAX, use appropriate value specified under recommended operating conditions.

[‡]All typical values are at V_{CC} = 5 V, T_A = 25 °C.

[§]Not more than one output should be shorted at a time, and duration of the short circuit should not exceed one second.

NOTE 3: Load circuits and voltage waveforms are shown in Section 1.

4

PROMS

TRP28L166
16,384 BITS (2048 WORDS BY 8 BITS)
LOW-POWER PROGRAMMABLE READ-ONLY MEMORIES WITH 3-STATE OUTPUTS

logic symbol

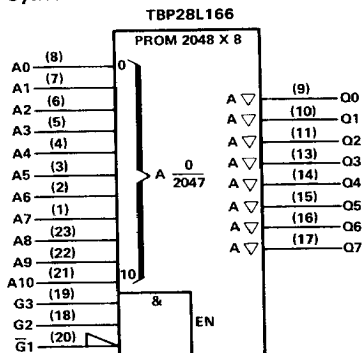

pin assignment

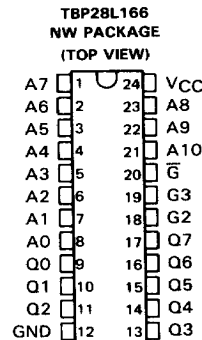

recommended operating conditions

PARAMETER	NW			UNIT
	MIN	NOM	MAX	
V _{CC} Supply voltage	4.75	5	5.25	V
V _{IH} High-level input voltage	2			V
V _{IL} Low-level input voltage				0.8 V
I _{OH} High-level output current				-1.6 mA
I _{OL} Low-level output current				8 mA
T _A Operating free-air temperature range	0			70 °C

4

PROMS

electrical characteristics over recommended operating free-air temperature range (unless otherwise noted)

PARAMETER	TEST CONDITIONS	NW			UNIT
		MIN	TYP [†]	MAX	
V _{IK}	V _{CC} = 4.75, I _I = -18 mA	-1.2			V
V _{OH}	V _{CC} = 4.75, I _{OH} = -1.6 mA	2.4	3.1		V
V _{OL}	V _{CC} = 4.75, I _{OL} = 8 mA	0.5			V
I _{OZH}	V _{CC} = 5.25, V _O = 2.4 V	50			μA
I _{OZL}	V _{CC} = 5.25, V _O = 0.5 V	-50			μA
I _I	V _{CC} = 5.25, V _I = 5.5 V	1			mA
I _{IH}	V _{CC} = 5.25, V _I = 2.7 V	25			μA
I _{IL}	V _{CC} = 5.25, V _I = 0.5 V	-0.25			mA
I _{OS} [‡]	V _{CC} = 5.25	-10	-100		mA
I _{CC}	V _{CC} = 5.25	75		110	mA

switching characteristics over recommended ranges of T_A and V_{CC} (unless otherwise noted)

PARAMETER	TEST CONDITIONS	NW			UNIT
		MIN	TYP [†]	MAX	
t _{a(A)} Access time from address	C _L = 30 pF	80			125 ns
t _{a(S)} Access time from chip select (enable time)	See Note 3	40			65 ns
t _{dis} Disable time	C _L = 5 pF See Note 3	30			65 ns

[†]All typical values are at V_{CC} = 5 V, T_A = 25°C.

[‡]Not more than one output should be shorted at a time, and duration of the short circuit should not exceed one second.

NOTE 3: Load circuits and voltage waveforms are shown in Section 1.

recommended operating conditions for programming (see Figure 1)

		MIN	NOM	MAX	UNIT
Steady-state supply voltage	V _{CC}	4.75	5	5.25	V
Input voltage	V _{IH}	3	4	5	V
	V _{IL}	0	0	0.5	
Voltage at all outputs except the one to be programmed		0	0	0.5	V
Supply voltage level to program a bit	V _{CC(pr)}	5.75	6	6.25	V
Select or enable level to program a bit	V _{S(pr)}	9.75	10	11	V
Output level during interval t ₅	V _{O(pr)}	15.75	16	16.25	V
Supply voltage during verification (see step 14)	Low	4.4	4.5	4.6	V
	High	5.4	5.5	5.6	
Time from V _{CC} to settle and to verify need to program	t ₁	0	5	10	μs
Time from V _{CC} = 6 V until chip select (enable) is at 10 V	t ₂	5	5	10	μs
Time from chip select (enable) high to start of program ramp	t ₃	0.1	5	10	μs
Ramp time, output program pulse	t ₄	10	15	20	μs
Duration of output program pulse	t ₅	15	20	20	μs
Time from end of program pulse to chip select (enable) low	t ₆	5	5	10	μs
Time from chip select (enable) V _{CC} = 0 V	t ₇	0.1	5	5	μs
Time for cooling between bits	t ₈	30	50	100	μs
Time for cooling between words	t ₉	30	50		μs
Free-air temperature	T _A	20	25	30	°C

step-by-step programming instruction (see Figure 1)

1. Address the word to be programmed, apply 5 volts to V_{CC} and active levels to all chip select (\bar{S} and \bar{S}) or chip enable (E and \bar{E}) inputs.
2. Verify the status of a bit location by checking the output level.
3. Decrease V_{CC} to 0 volts.
4. For bit locations that do not require programming, skip steps 5 through 11.
5. Increase V_{CC} to V_{CC(pr)} with a minimum current capability of 250 milliamperes.
6. Apply V_{S(pr)} to all the \bar{S} , \bar{E} or \bar{G} inputs. I_I ≤ 25 milliamperes. Active-high enables may be left high.
7. Connect all outputs, except the one to be programmed, to V_{IL}. Only one bit is to be programmed at a time.
8. Apply the output programming pulse for 20 microseconds. Minimum current capability of the programming supply should be 250 milliamperes.
9. After terminating the output pulse, disconnect all outputs from V_{IL} conditions.
10. Reduce the voltage at \bar{S} , \bar{E} , or \bar{G} inputs to V_{IL}.
11. Decrease V_{CC} to 0 volts.
12. Return to step 4 until all outputs in the word have been programmed.
13. Repeat steps 2 through 11 for each word in memory.
14. Verify programming of every word after all words have been programmed using V_{CC} values of 4.5 and 5.5 volts.

4

PROMS

**SERIES 24 AND 28
PROGRAMMABLE READ-ONLY MEMORIES**

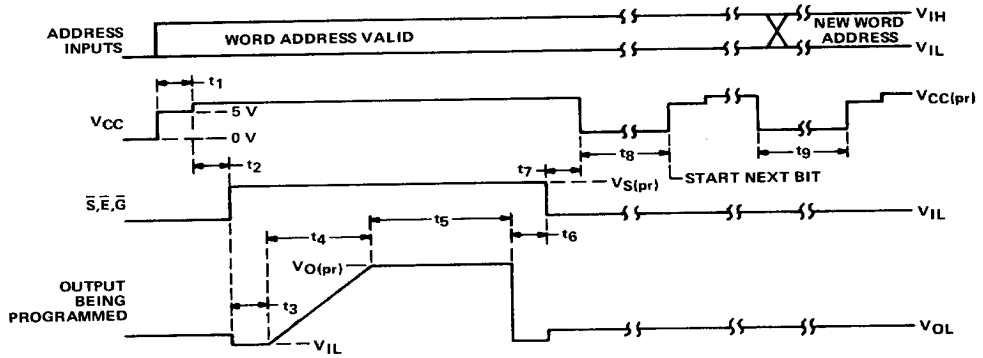

NOTE 4: Rise and fall times should be $\leq 1 \mu s$.

FIGURE 1. TIMING DIAGRAM AND VOLTAGE WAVEFORMS FOR PROGRAMMING SEQUENCE

4

PROMs